

SOUTHWEST WASHINGTON FAIR



2017 Grange Book

John Schaefer, Superintendent

2017 Fair Theme:

"I'm A Fair Kid!"

GENERAL RULES

The intent and purpose of your Fair booth is to create a display that shows the variety and quality of Lewis County Agriculture. Many times these booths educate as to the product used and produced on your farms. It is preferred that all items have been made or harvested in Lewis County.

Grange booths portray agricultural life and quality. The educational value and manner in which it is shown is the major part of judging. In order to maintain quality displays, the Southwest Washington Fair pays every exhibit. Maintenance and Supervision of the Grange Aisle is expected during the Fair. Participating Granges will provide persons to patrol each day of the Fair. All produce in all booths must be checked for spoilage and replaced during the fair by the exhibitors.

Being a good neighbor is a large part of agricultural life. Exhibitors need to assist each other by: not crowding beyond assigned space with exhibit or setup room; completing all carpentry before 8:00 p.m. **Sunday** prior to the Fair; not using decorations, lights, etc. that hide or detract from adjacent booths and completing the display by 8:00 p.m. **Monday** before the Fair opens on Tuesday. Do not decorate gates.

Two or more Granges may join together in a booth if so desired. All booths must be designed and constructed by Lewis County Grangers.

Judging of the booths is done by persons selected by the Grange Superintendent and must be selected from another county and have expertise in the field of agriculture. Judges must use a scorecard adopted by exhibiting Granges. Changes in procedures and rules are permissible if commonly accepted and all participants are notified in time to adjust to changes.

Any rule interpretations are to be made by the Grange Superintendent. Modifications and interpretations of the rules should be discussed with the Pomona Fair Committee and filed in the Fair Office before August 1st. Examples of these could be: changes in number, additions or deletions to necessary or permissible items or maturity. Because of fluctuations in weather patterns, these are frequent problems.

The Grange Building is located between the Floral and Wildlife Buildings. The building is open from 10:00 AM to 10:00 PM daily, and Sunday from 10:00 AM until 7:00 PM. Remember your building is here for the public, not your convenience.

Premium checks will be mailed after Fair.

TRADITIONAL

The Traditional Grange booth attempts to portray the total agricultural production within the Fair or Grange Theme and still tell an educational story. It's preferred that the produce be grown in Lewis County. These displays may include:

- threshed seed, ½ pint each
- grains or grasses - 2 sheaves each
- fruit, 2 must be apples
- fresh garden vegetables
- canned vegetables/fruits
- glasses jams/jellies in ½ pint
- home produced miscellaneous products
- (Use uniform size jars)

Use a variety and as many of each of these items needed to make a nice, balanced display. A border may be used around the edge of the display, if desired.

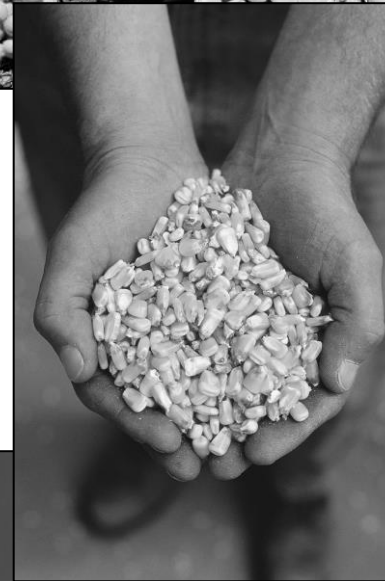



The Traditional Grange booth scorecard would be:

Seeds	100
Grains/Grasses	120
Fruit	100
Vegetables	100
Canning	100
Jams/Jellies	80
Miscellaneous	100
Theme	100
Arrangement/Alignment	200
(Color, Lighting, Printing	
Quality of Produce)	<hr/>
	1000

Each requirement up to 10 points based on quality.

PREMIUMS

- 1st Place ----- \$150.00
- 2nd Place ----- \$125.00
- 3rd Place ----- \$100.00

The following lists and instructions are provided to assist your display, and to explain the judging. Remember, these are minimums and additional items may be included to assist design, theme or educational value of the booth. Additional items may detract from your score if inferior to other items! Check booths for spoilage during Fair week and replacements must be made as needed, especially berries.

THRESHED SEEDS -

Containers must be uniform in size and shape. Superintendent will open containers during judging. Use as many as needed for balance and arrangement.

1. Wheat
2. Barley
3. Oats

4. Rye

5. Corn
6. Beet
7. Sunflower
8. Any Grass (Clover, Timothy)
9. Any Garden Vegetable (Peas, Beans)
10. Tree Seeds
11. Any Other
12. All seeds must be labeled

Judging - These are seeds, they will be judged on their ability to reproduce plants and to store well. Cracked, broken, immature, insects, diseased, dirt, foreign objects and dryness all affect seed quality.

GRAINS AND/OR GRASS SHEAVES - Use as many from the list below - using as many as needed for balance and arrangement.

1. Wheat
2. Barley
3. Oats
4. Rye
5. Clover (maximum 2 varieties)
6. Timothy
7. Rye Grass
8. Canary
9. Alfalfa
10. Vetch
11. Fescue
12. Orchard Grass
13. Any Other

Uniform length, leaves stripped (#1-4), leaves on bloom (#5-13), 2-3 ties, may be decorative, 2" center diameter (minimum). On smaller booths may be 1" (minimum).

Judging - Grains are judged on brightness of color, maturity and uniformity. Grasses are judged on color, bloom appropriate to quality.

People's Choice - The Bowman Grange Insurance of Centralia donates plaques to the Traditional and Contemporary booths receiving the highest score from voters visiting Grange Aisle during the week of the Fair. Granges wishing to enter this contest pay a \$10.00 entry fee. Traditional and Contemporary will split the entry fees. Premium amounts may vary according to number of entries.

GRANGE DAY

Wednesday, August 17, 2015

Wednesday of fair week is designated as Grange Day.

Each subordinate Grange is asked to help secure performers for this popular event. The Grange Aisle Entertainment Coordinator, Shirley Kimball (360.330.0969), must be notified by August 1 in order to have the program printed by Fair.

AWARDS

Traditional - A rotating trophy, donated by Radio Station KELA is awarded to the outstanding Traditional display in the Grange Department at the Southwest Washington Fair. This award has been given continuously since 1946. The winning Grange has possession of the trophy until the following year's Fair.

A plaque is awarded yearly to the Traditional display receiving highest points in ARRANGEMENT. This plaque is donated by the Cowlitz Prairie Threshing Bee.

Contemporary - A rotating trophy donated by Awards West is given to the outstanding Contemporary display in the Grange Department at the Southwest Washington Fair. The trophy remains with the winning Grange until the following year's fair.

A plaque is donated yearly by The Farm Store, of Chehalis, Washington to the CONTEMPORARY Grange receiving the highest score for ARRANGEMENT. This plaque is given permanently to the winning Grange.

Cleanliness, storage ability, freedom of shatters, disease, insects and foreign material, improve quality and freshness.

FRUIT - 2 varieties of apples required. (stems required)

Use as many of each variety as necessary to provide balance in the overall display.

1. Apples - stems required
2. Pears - stems required
3. Prunes/Plums - stems required
4. Crab Apples - stems required
5. Grapes (green or mature)
6. Any kind Berry (each counts as one)
7. Quince (leaves optional)
8. Any Variety Nut (each counts as one)
In or out of shell.

Judging - All fruit is judged on its edible quality. Free of blemish, injury, insects, disease and uniformity of size and color are major factors in judging. Immaturity is not a factor, but must be marketable. It is preferred that all are grown in Lewis County.

VEGETABLES--Use whatever number of each you wish, but remember: **Balance in the Display.**

1. Squash - 1-2" stem, clean
2. Pumpkin - 1-2" stem, clean
3. Cauliflower - 1-2" stem, clean
4. Cabbage - protective layer optional
5. Broccoli
6. Brussels Sprouts - protective layer optional

7. Turnip - 1-1 1/2" top, clean, mature, clip root
8. Carrot - 1-1 1/2" top, clean, mature, clip root
9. Table Beet - 1-1 1/2" top, clean, mature, clip root
10. Rutabaga - do not scrub
11. Potato - do not scrub
12. Parsnip
13. Peas, pod
14. Beans
15. Pepper - 1/4-1/2" stem
16. Cucumber
17. Tomatoes - green or red - 1/2-1" stem
18. Kohlrabi - square root
19. Onion - 1-1 1/2" stem, may remove dry skin, clip root
20. Rhubarb - 1" stem, trim square
21. Sweet Corn - trim silk, tear open, window square

Judging - Vegetables are judged on uniformity of size, color and maturity. Free of insect, blemish, disease and uniformity add to quality. Rules of display are based on maintaining quality during storage. Care in cleaning must be observed to maintain the natural protective qualities of the vegetable skin.

CANNED GOODS - Use standard quarts or pints
 Vegetables/Meat/Fruits - whatever is needed for balance.
 Use 1/2-pint glasses jams and/or jellies

Judging - Attractiveness, fullness of jar, no floating and uniformity of containers are considered in determining quality. Cleanliness, brightness and sealed jars add to the quality. Air space should be covered by normal ring. Old products will fade and settle with age. Check seal before placing in display.

Premiums

1st Place	90-100 Points	\$60.00
2nd Place	80- 90 Points	\$40.00
3rd Place	70- 80 Points	\$20.00

Junior Granges are not based on competition, but quality. Judges may set levels of quality for blue or red. Rosettes will be awarded according to scores.

BOOTH SIZE

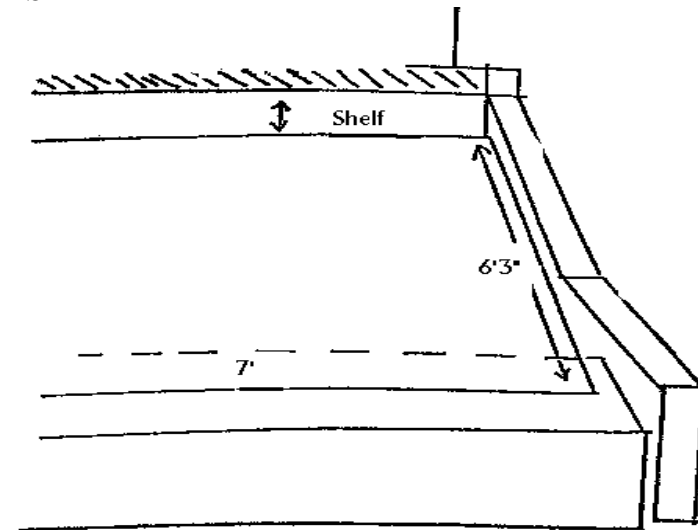

No crafts or trophies from other fairs or contests. Junior Fair booths are painted plywood and lumber. These are permanent fixtures. The Southwest Washington Fair works with the Grange Department in remodeling and maintenance

Please remove all staples and nails from the booth during your regular tear down time. Measure before planning your display. No decorations on gates or top of slope sides.

JUNIOR GRANGE

This is an opportunity for junior members to display their activities and workmanship and to compete with other junior granges. The same general rules, intents and purposes exist for the Juniors as well as other Granges. However, ages of the Juniors should be considered by the Judges. Junior Grange Booths are to be designed and created by children between the ages of 5 and 14 and should portray their activities, goals and interests. Adult assistance must be limited to instruction and supervision. Adults are advisors not participants in the work of putting in a booth. Remember this is a Junior Project. Give children's ages to Superintendent.

The booth itself is a craft project. This booth may follow the Fair Theme or the Grange Theme.

Score Card

Theme (Objective)	200
Design, attractiveness and appeal	200
Originality, Educational Value	400
Quality of workmanship	<u>200</u>
	1000 points

MISCELLANEOUS - 10 of the following - labeled

1 Pint Glass

- | | |
|-----------------|----------------|
| Lard | Tallow |
| Extracted Honey | Butter |
| Chicken Fat | Cottage Cheese |
| Herbs | Nut Meats |
| Juices | Syrups |
| Powdered Milk | |

Plate or Other

- | | |
|------------------|-----------------------------------|
| Flower Bulbs - 6 | Bread - 1 |
| Rolls - 6 | Tree Cones – 6 (from local trees) |
| Garlic - 6 | Salal |
| Holly | Wool |
| Comb Honey | Herbs - <u>Dry</u> |
| Soaps | Nuts |
| Beeswax | Dried Product |

- 2 dozen Eggs
- Flowers - Do not hide display
- Cascara - any diameter

Judging - Based on quality, home produced, attractiveness and ease of identification.

Theme

The theme of a display should unite the total display. It serves as a focal point, an attraction, but most of all creates a comfortable feeling and answers the question WHY (?).

The Central Theme of any Grange Booth is to portray agriculture in our area. A means of doing this is the Grange Theme or the Fair Theme.

ARRANGEMENT (Design)

Elements of proper design create harmony, comfort and pleasing atmosphere. Color, mass and texture are the components of any picture. These must occur as complimentary units not individual items. Repeating geometric patterns usually makes these three complimentary. People often refer to this as balance. A large pumpkin can be balanced with a box of carrots for color and mass, though varying greatly in texture. To maintain a basic design rule, vary only one component at a time.



Is it informative? -- 150 Points

New information in old circumstances is valuable. "Cholesterol found in eggs is not harmful". "Powdered milk helps stabilize milk prices." You've told the story, what's the punch line?

Originality? -- 100 Points

Nothing is new! However, by adding two old things, new ones are made. Add a dill pickle to a peanut butter sandwich, it's new! Take the bone out of a T-bone steak, it's new! What have you done different?

ARRANGEMENT -- 200 POINTS

Contemporary fair booths are painted plywood and lumber. These are permanent fixtures. The Southwest Washington Fair works with the Grange Department in remodeling and maintenance. Remember, as the building is used throughout the year, wear and tear does occur. All nails and staples used must be removed by parties using building. These booths have risers with slopes.

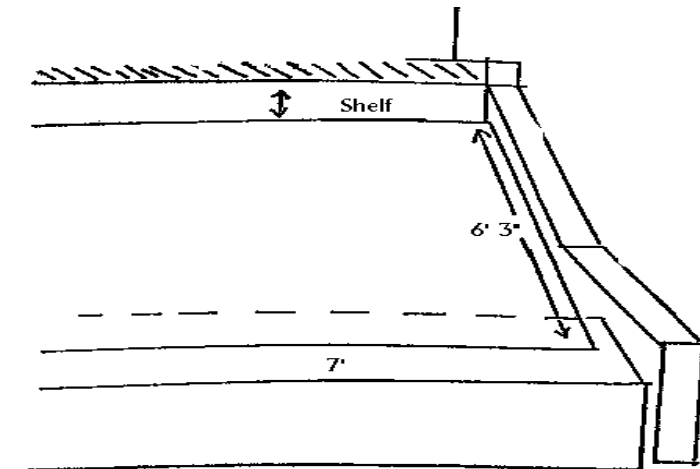

Measurements are approximate. Measure your booth before planning the design.

Think of loading a wagon. Will it ride good or will it tip and sway?

Does it have balance in color?

Color balance is like weight and mass balance. A single color should not appear just once. A color should follow through in a recognizable line or reappear in a different amount. The fewer the colors, the easier to create an attractive display.

Are products used of good quality?

Uniform quality makes a comfortable display. An outstanding piece of work will detract from good pieces. Poor work and workmanship is recognizable by everyone. Do not try to get by - it will be noticeable.

Does it have effective lighting?

All booths have good lighting. However, additional spot lights to focal points may highlight parts of your display. A more common problem is one of creating shadows and hiding a part of the display. Do not use materials higher than booth walls. They block the view from either side.

EDUCATIONAL VALUE

Is it interesting? -- 150 Points

After you have stopped someone to look, what did you say? Is it worth repeating? If it is, it's interesting. Remember, what is common to you may not be to others. "This tree was 40 years old when Columbus sailed", is interesting.

Does it have balance in arrangement?

This does not mean symmetrical. Weight and mass equalized throughout the display makes it comfortable.

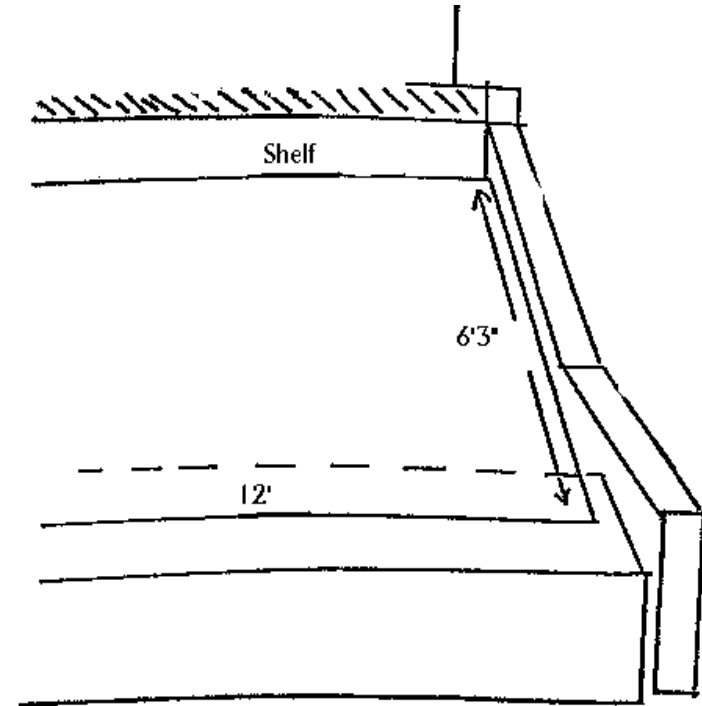

Before planning a booth, come in and look. Unloading and loading will be at the back entrance. It is best to have a dolly. Lighter items may be carried in at the front entrance. Plan on putting your backboard and bins in before Monday of Fair week.

This category is available for those Granges with varying resources of time, people, facilities or a special subject interest. A freedom of materials, theme and the opportunity to vary display, create an active alternative for many Granges.

The Scorecard is simple:

Central Theme (objective)	200
Attractiveness	200
Educational Value	400
Arrangement	200

	1000

Premiums

1 st Place - - - -	\$100.00
2 nd Place - - - -	\$ 90.00
3 rd Place - - - -	\$ 80.00
4 th Place - - - -	\$ 60.00
5 th Place - - - -	\$ 40.00
All Other - - - -	\$ 30.00

(Ribbons awarded 1st-8th Place)

The contemporary booths share the major objectives of the Grange Department - to show the values and traditions of agricultural life in Lewis County. The judge's scorecard tries to measure this.

CENTRAL THEME – Either the The Fair Theme of *“Fair In Full Bloom”* or the Grange Theme of *“Garden In Bloom”* may be used. Either theme must tell an agricultural story. For more information contact the Grange Superintendent.

Grange Aisle Superintendent is John Schaefer (360.785.4305)

Does it tell a story? -- 75 points

When a display has an objective, everything seems to fit. In developing a booth, determine what you want to say then get materials and ideas to say it!

Does it tell an effective Agricultural story? -- 50 points

Do viewers know what you are trying to say? Remember, you've been working with an idea for a long time, the viewer sees many ideas. Can he see why you have done what you have?

Does it tell a story completely? -- 50 points

Don't stop at an assumption! Say it! Do not hide facts or mislead viewers. Commercial booths say loud and clear, "my product is what you need, buy it." Your booth should tell its message with the same clarity.

Does it tell a story quickly? -- 25 Points

The average Fair viewer sees two booths at a time for 10 steps, less than 1/2 minute. Can he receive your message in 15-20 seconds? Many TV commercials are shorter. Any printing must be well done and easy to read from a distance!

ARRANGEMENT

Does it draw attention? -- 200 points

Size, color, movement, sound and light in unique or uncommon circumstances draw attention. Keep it simple, even if it is a combination of these. A pink cow is attention, however, if it talked and moored, it would be more so. Do not have too many attention getters unless they appear as one.